



"The ART of Noise Control"

For your local ArtUSA Representative

Call: 1-888-454-6973

Internet: www.artusaindustries.us

Sound Attenuator

NO. 770-90

ENGINEERING DATA SHEET

MODEL HP-TL

RECTANGULAR

NOMENCLATURE EXAMPLE:

WIDTH	HEIGHT	LENGTH	MODEL
24	24	3	HP-TL

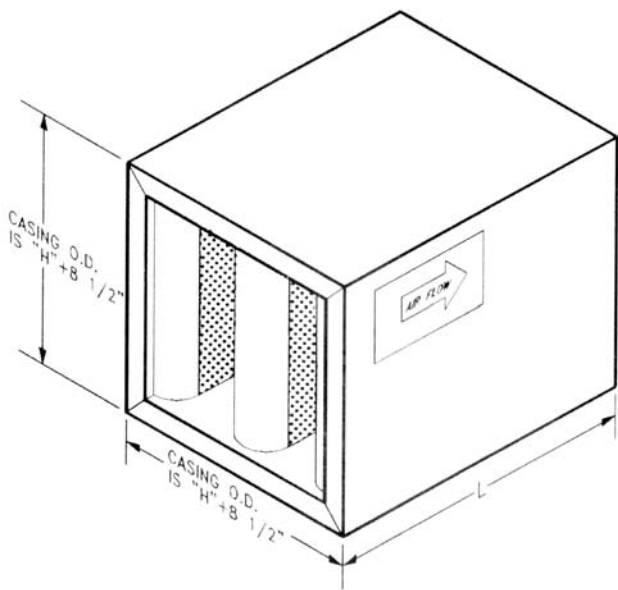

ArtUSA Acoustics sound attenuators are engineered to achieve a maximum insertion loss with a minimum pressure drop. ArtUSA Acoustics sound attenuators feature airfoil design for efficient aerodynamic performance, as well as superior acoustical materials and totally galvanized steel construction, guaranteeing excellent reliability and performance. **HP-TL** Sound Attenuators provide the physical and acoustical security required to meet the **Sound Transmission Class (STC)** ratings for today's security conscious environments. *Optional RF shielding can be added for 'Tempest' applications.*

MODEL NO.	OCTAVE BANDS	(1)	(2)	(3)	(4)	(5)	(6)	(7)	(8)
	CENTER FREQUENCY (Hz)	63	125	250	500	1000	2000	4000	8000
	FACE VELOCITY FPM	DYNAMIC INSERTION LOSS IN DECIBELS							
5HP-TL	-1500	9	17	36	46	48	40	34	22
	-1000	8	16	33	45	51	44	41	22
	0	7	13	29	42	58	62	45	25
	+1000	6	12	26	40	57	60	48	27
	+1500	6	12	25	39	54	51	45	28
7HP-TL	-1000	11	24	39	43	49	47	39	30
	-500	11	23	38	48	52	49	43	33
	0	9	19	36	47	50	48	45	34
	+500	8	16	34	46	50	49	45	35
	+1000	8	16	33	45	50	48	44	36
10HP-TL	-1000	13	24	42	54	56	53	50	41
	-500	12	23	41	53	55	54	51	42
	0	12	22	40	52	54	54	52	42
	+500	11	21	40	52	53	54	52	43
	+1000	10	19	39	52	53	54	51	46

THIS TABLE CONTAINS BOTH FORWARD (+) AND BACKWARD (-) FLOW ACOUSTIC AND AERODYNAMIC RATINGS BASED ON TEST RESULTS MEASURED IN ACCORDANCE WITH ASTM E477. COPIES OF THESE TEST REPORTS CAN BE FURNISHED UPON REQUEST.



"The ART of Noise Control"

For your local ArtUSA Representative

Call: 1-888-454-6973

Internet: www.artusaindustries.us

Sound Attenuator

RECTANGULAR
MODEL HP-TL

ENGINEERING DATA SHEET

AIR FLOW RATING FOR THE 12 X 12 SIZE, SHADED, REPRESENTS BOTH CFM AND FACE VELOCITY IN FPM.
USE THIS TO GET THE RATING FOR MULTIPLE MODULE SILENCERS.

MODEL	5HP-TL	.045	.078	.110	.142	.168	.190	.220	.285	.349	.485	.647	.808
	7HP-TL	.060	.102	.145	.187	.222	.251	.290	.376	.460	.640	.853	1.066
	10HP-TL	.058	.099	.140	.181	.214	.242	.280	.363	.445	.617	.824	1.029
SIZE W x H	FACE AREA	AIR FLOW IN CFM											
6 x 12	0.50	227	297	354	402	438	465	500	569	630	743	858	959
6 x 24	1.00	454	594	707	804	875	930	1000	1138	1260	1485	1715	1917
6 x 36	1.50	681	891	1061	1206	1313	1395	1500	1707	1890	2228	2573	2876
12 x 12	1.00	454	594	707	804	875	930	1000	1138	1260	1485	1715	1917
12 x 24	2.00	908	1188	1414	1608	1750	1860	2000	2276	2520	2970	3430	3834
12 x 36	3.00	1362	1782	2121	2412	2625	2790	3000	3414	3780	4455	5145	5751
18 x 12	1.50	681	891	1061	1206	1313	1395	1500	1707	1890	2228	2573	2876
18 x 18	2.25	1022	1337	1591	1809	1969	2093	2250	2561	2835	3341	3859	4313
18 x 30	3.75	1703	2228	2651	3015	3281	3488	3750	4268	4725	5569	6431	7189
18 x 36	4.50	2043	2673	3182	3618	3938	4185	4500	5121	5670	6683	7718	8627
18 x 48	6.00	2724	3564	4242	4824	5250	5580	6000	6828	7560	8910	10290	11502
24 x 24	4.00	1816	2376	2828	3216	3500	3720	4000	4552	5040	5940	6860	7668
24 x 36	6.00	2724	3564	4242	4824	5250	5580	6000	6828	7560	8910	10290	11502
24 x 48	8.00	3632	4752	5656	6432	7000	7440	8000	9104	10080	11880	13720	15336
30 x 24	5.00	2270	2970	3535	4020	4375	4650	5000	5690	6300	7425	8575	9585
30 x 36	7.50	3405	4455	5303	6030	6563	6975	7500	8535	9450	11138	12863	14378
30 x 48	10.00	4540	5940	7070	8040	8750	9300	10000	11380	12600	14850	17150	19170
36 x 36	9.00	4086	5346	6363	7236	7875	8370	9000	10242	11340	13365	15435	17253
36 x 42	10.50	4767	6237	7424	8442	9188	9765	10500	11949	13230	15593	18008	20129
36 x 48	12.00	5448	7128	8484	9648	10500	11160	12000	13656	15120	17820	20580	23004

Air flow ratings shown include static regain. Therefore if silencers are installed immediately before or after elbows, transitions, at the intake or discharge of the system, or without duct, allowance to compensate for such conditions must be included when calculating the operating pressure loss thru the silencer. Failure to make allowance for these conditions can add several velocity heads to the pressure loss of the system. All acoustic and aerodynamic performance obtained on 24" x 24" cross section production units.

SELF-GENERATED SOUND POWER RATINGS (PWL)

dB re 10⁻¹² WATTS

OCTAVE BAND		1	2	3	4	5	6	7	8
HZ		63	125	250	500	1000	2000	4000	8000
MODEL	FACE VELOCITY								
5HP-TL	+1500	62	61	54	50	49	55	55	52
7HP-TL	+1000	55	51	42	41	42	43	40	37
10HP-TL	-1000	54	52	50	52	55	60	55	46
	-1500	63	56	54	57	60	63	66	60

SELF-GENERATED SOUND RATINGS/FACE AREA ADJUSTMENT FACTORS

FACE AREA	.50	1	2	4	8	10	32	64	128
PWL ADJUSTMENT FACTOR, dB	-9	-6	-3	0	+3	+6	+9	+12	+15